



# MMC-T Modular Stepper Controller/Drive



## MODULAR CONTROLLERS

- Stand Alone Single Axis
- Press Together Multi-Axis
- Mix & Match Axis Types
- Expansion I/O Modules
- Auto Detect Connected Modules
- Auto Configure for Replacement
- Customization Available

## FLEXIBLE HARDWARE

- Removable Connectors
- Configurable Digital/Analog I/O
- Multiple Encoder Types
- High Speed Capture
- Integrated Amplifier Options
- Din-Rail Ready

## POWERFUL SOFTWARE

- Inspired by MIT's "Scratch"
- Simple Drag, Drop, & Edit
- Create & Save Custom Blocks
- Up to 16 Concurrent Threads
- Parameter Test & I/O Viewer
- Integrated HMI Console Builder
- Customizable Test Scopes



The MMC-T is a Single Axis Modular Stepper Motor Controller with Integrated Amplifiers.

Modular Controllers give users the power of a Multi-Axis Motion Controller with the flexibility to add Axes in a Modular Fashion. A single Axis Controller instantly becomes a multi-axis controller when snapped onto another controller. Due to the nature of the connection, no change of control or programming architecture is needed; the software simply recognizes that it has more available axes and I/O to utilize.

Inspired by MIT Media Labs "Scratch" software that was developed to teach the fundamentals and structure of programming

## KEY FEATURES:

- Integrated Stepper Motor Controller & Driver
- 12-48Vdc Input, 6A Output
- Microstepping at 256  $\mu$ Steps/Full Step
- (4) Dedicated Inputs (24V)
- (2) Programmable Digital I/O
- (1) 16-bit Analog Input
- (1) 16-bit Analog Output
- Flexible Encoder Inputs (Single, Quad, Serial, etc.)
- Closed Loop Control of a Stepper
- Separate Logic Power Input
- Pluggable for Multi-Axis Configuration
- USB, Ethernet, and Serial Communication

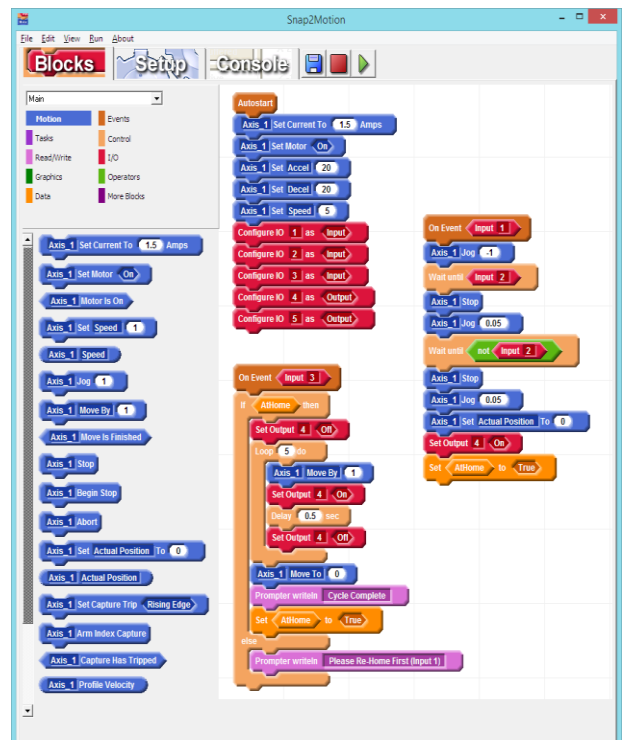

Learn More at: [www.ModuSystems.com](http://www.ModuSystems.com)

# Specifications

## Controller Power

Description	Value	Units
Logic Input Voltage Range	12-48	volts DC
Logic Input Power, no outputs active, no 5V load, single module	3	watts
Motor Bus Voltage Range	12-48	volts DC
Motor Drive Current Per Phase	6	amps
5V Out	750	milliamps

## Motion System

Property	Value
Microcontroller	Arm Cortex
Sample Rates	Configurable from 1 kHz to 8 kHz
Native Motion Capabilities	Concurrent Motion Coordinated Vector Motion
Application Motion Capabilities	Electronic Gearing Electronic Camming Encoder-Replaces-Time PVT Kinematics Conveyor Tracking Arbitrary Closed Form Equations
Position Range	32 bit
Maximum Encoder Count Rate post quadrature	2 MHz
Maximum Step Rate	2 MHz
Hardware Position Capture	Accurate to an individual count

## Communication Ports

Description	Type	Connector
Programming Port	USB	USB Standard B
General Purpose Serial	RS232 or RS485 Run-time configurable	3 pin 3.81 mm Euro Screw terminal
General Purpose Ethernet	TCP/IP server supporting 8 concurrent ports	Single RJ-45

## Inputs and Outputs

Resource	Number	Voltage	Description
Configurable Digital IO	2	5--48	2 amps sourcing output current optoisolated input is sourcing or sinking as group
Dedicated Digital Input	4	5-48	Optoisolated sourcing or sinking as a group
Analog Input	1	0-20	0-20 volt measurement range. Clamps permit voltage up to 48 volts on pin. 16 bit resolution
Analog Output	1	0-5	12 bit resolution
Encoder Inputs RS422 Differential Receivers	3	5-24	A, B, and Index channels can be used for encoder input or general purpose inputs

## Mechanical

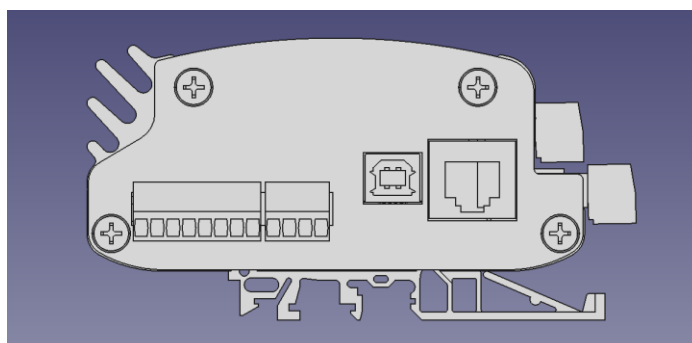
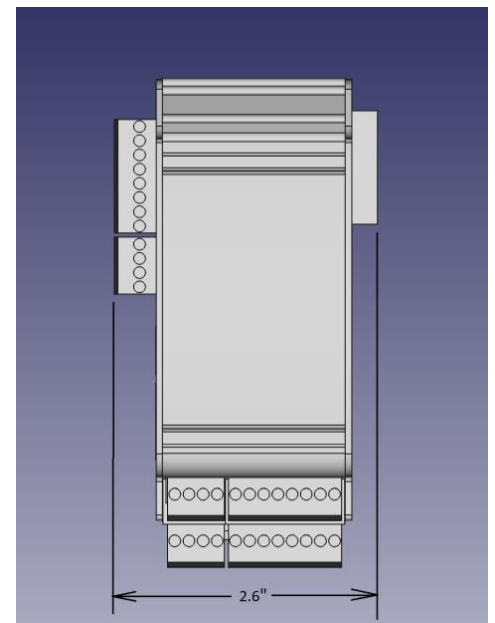
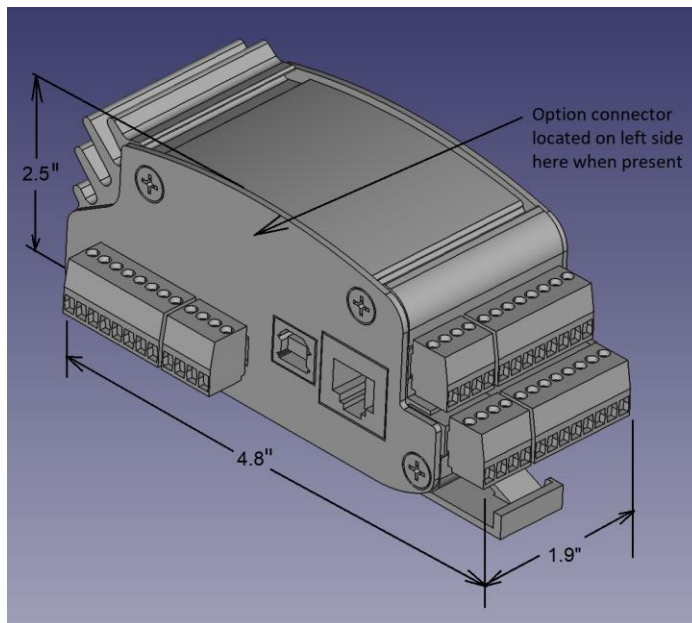

Clearance required for right side connector. Insure clearance is provided for airflow around heat sink fins when operating at higher current levels. Avoid mounting controller inverted as this traps air in the heat sink fins. Insure clearance on left side for wiring, USB, and Ethernet connectors.

## EStop Connector - Left Side 8 Position

The first three positions of the EStop connector are for application use. The remaining positions are used for communication to snapped-together modules. No connections should be made to the remaining 5 positions.

Signal	Description
Gnd	Provides Gnd to snapped-together modules. May be used as a general purpose Gnd connection position
Logic Pwr	Provides Logic Power to snapped-together modules. May be used as a general purpose Logic Power position and is often jumpered to the adjacent EStop position to satisfy EStop
EStop	This hardware EStop input must be satisfied to permit motion. The signal is satisfied by being connected to 5-48 volts. This connection usually incorporates normally closed EStop buttons so that the opening of a button, or breakage of a wire, performs a shutdown

## Serial Connector - Left Side 3 Position

The serial connector can support RS232 or RS485 based on software configuration. When using RS485 a termination resistor is recommended to insure failsafe signal management features operate properly. For noisy environments an external failsafe bias circuit is recommended.

Signal	Description
Gnd	Common to all Gnd positions on controller this is used to provide a common Gnd to the serial device
Rx/+	RS232 receive signal should be connected to transmitter of serial device. When configured for RS485 this is the Data+ signal
Tx/-	RS232 transmit signal should be connected to receiver of serial device. When configured for RS485 this is the Data- signal.

**P**

## Intermodule Plug Connector – Right Side 8 Position

The plug style connector on the right side of the controller is only used to provide power and communication to snapped-together modules. No connections should be made to this plug connector.

## Power Connector – Front Side Top 4 Position

Signal	Description
Gnd	Used for power supply return connection
Logic Pwr	Used for power supply “+” connection. It is recommended that Logic Power not be interrupted by safety disconnects so as to sustain program operation and communications with host
Mtr Pwr	Motor Power provides voltage to the internal drive. Safety standards that require disconnecting drive power can be satisfied by disconnecting this position.
In Common	Input Common is used to configure inputs as sourcing or sinking. If signals provide voltage then connect In Common to Gnd. If signals act like switches to Gnd then connect In Common to Logic Pwr

## Encoder Connector – Front Side Top 8 Position

Signal	Description
Gnd	Used to power encoder
5V Out	Used to power encoder. If external drive is providing signals this signal might not be required
Enc A+	Encoder A+ channel if differential or A channel if single ended
Enc A-	Encoder A- channel if differential or disconnected if encoder is single ended. Internally pulled to 2V. Do not connect to Gnd
Enc B+	Encoder B+ channel if differential or B channel if single ended
Enc B-	Encoder B- channel if differential or disconnected if encoder is single ended. Internally pulled to 2V. Do not connect to Gnd
Enc I+	Encoder Index+ channel if differential or Index channel if single ended
Enc I-	Encoder Index- channel if differential or disconnected if encoder is single ended. Internally pulled to 2V. Do not connect to Gnd

## Motor Power Connector – Front Side Bottom 4 Position

Signal	Description
Mtr A+	Connect to one end of first motor phase
Mtr A-	Connect to opposite end of first motor phase
Mtr B+	Connect to one end of second motor phase
Mtr B-	Connect to opposite end of second motor phase

# Front IO Connector and Indicators

## IO Connector – Front Side Bottom 8 Position

If an input is needed and a dedicated input is available it is best to use the dedicated input and preserve the more versatile DIO positions for outputs or spares

Signal	Description
DIO 1	Digital Input Output 1 can be configured as an input or an output
DIO 2	Digital Input Output 2 can be configured as an input or an output
DIN 3	Digital Input 3 is a dedicated input
DIN 4	Digital Input 4 is a dedicated input
DIN 5	Digital Input 5 is a dedicated input
DIN 6	Digital Input 6 is a dedicated input
AIN	Analog Input
AOUT	Analog Output

## LED Indicators

LED	Description
Green Heartbeat	During normal operation this LED should blink at a rate between 1 Hz and several Hz reflecting the controller sample rate. A hesitation or disruption of the steady heartbeat pattern reflects a possible hardware or software issue. The first diagnostic question support will ask is "Is the Heartbeat LED blinking?".
Yellow Application	This indicator is under application program control and has no intrinsic meaning. The Intermodule Slave program, loaded onto controllers that snap onto a left-most master controller, rapidly blink the Yellow Application LED several times during program startup when the controller is isolated. This pattern indicates that the controller is prepared to snap onto another module.
Ethernet Green Link Active	The link active light indicates that there is traffic on the Ethernet cable and that both ends are connected. If there are any issues with Ethernet first confirm that the link is active.
Ethernet Yellow 10/100	This indicator shows the connection speed

# 3ENC Option

## Description

The 3ENC Option board provides support for three encoders, each with RS422 differential inputs for A, B, and Index signals from a 3 channel encoder. These additional encoders can be used for purposes such as master position references, dual loop, and hand wheel inputs. The 25 pin DSub connector is presented on the left side of the controller above the USB connector. Power for the encoders on this option board are part of the controller's +5V current budget.

## Pin Assignments

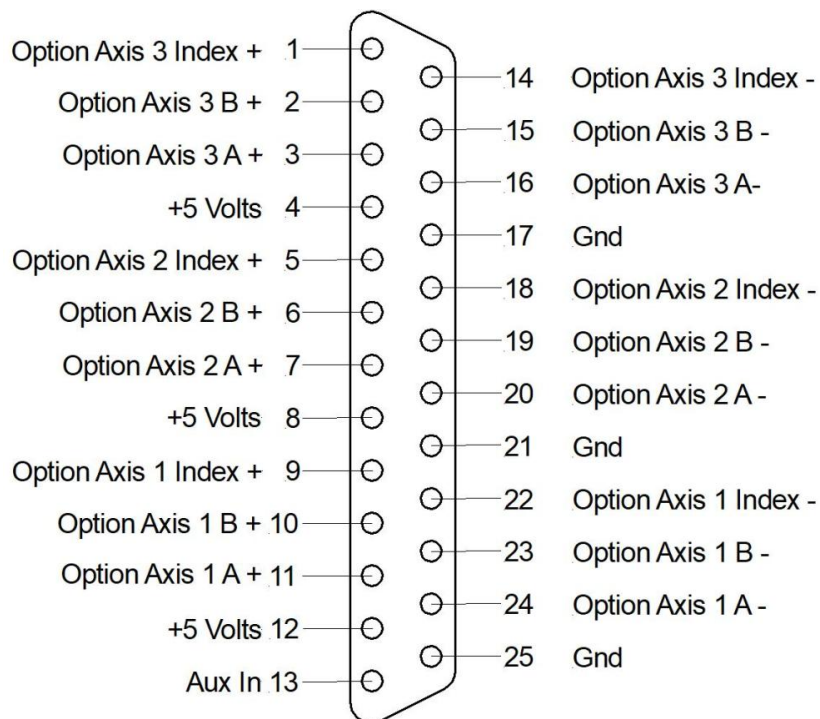

## Option Specifications

Description	Value	Units
Input Signal Voltage Range	5-24	volts DC

# 3PD Option

## Description

The 3PD Option board provides support for additional motion axes expressed as signals for use with external drives. These signals can be configured as Pulse/Direction signals or as driven quadrature signals for use with external stepper motor drivers or servo motor drivers that can accept external pulse/direction or external quadrature signals that the drive follows. Motion signals are RS422 differential outputs. If available, the quadrature format is desirable as it is more noise immune than pulse/dir however with good wiring practice either format is reliable. An input for each axis is provided and is most often used for homing. This input is the “+” side of a differential receiver where the “-” side is tied to a 2 volt internal reference.

When working with Teknic drives it is best to connect the “+” side of the Teknic signal to the +5V pin on the option connector and the “-” side of the Teknic signal to the Step- or Dir- signal on the option connector. Differential drivers do not meet the voltage requirements for Teknic inputs but the described configuration does.

## Pin Assignments

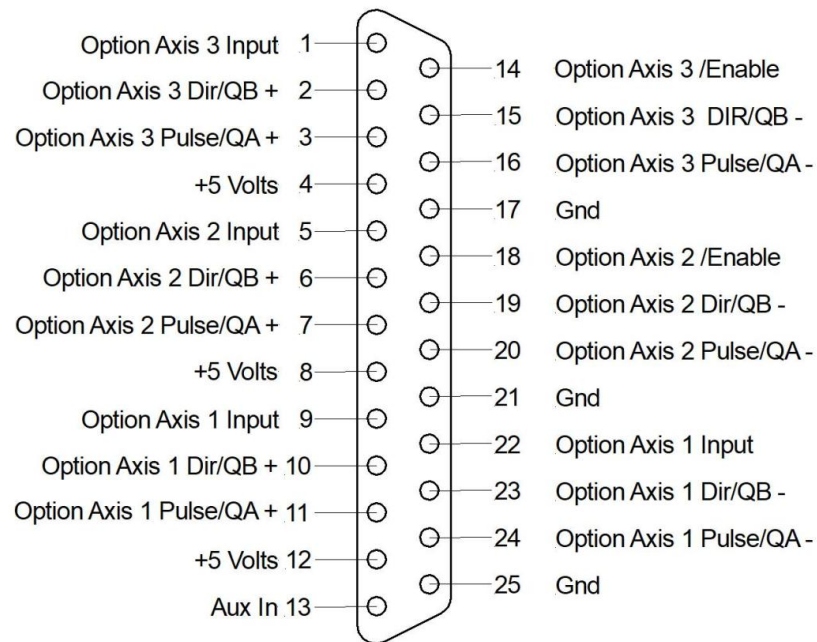

## Option Specifications

Description	Value	Units
/Enable Max Voltage	35	volts DC
/Enable Max Current	30	milliamps
Input (+ side of RS422 receiver)	5-24	volts DC